

1090 FRAMELESS HEAVY GLASS DOOR

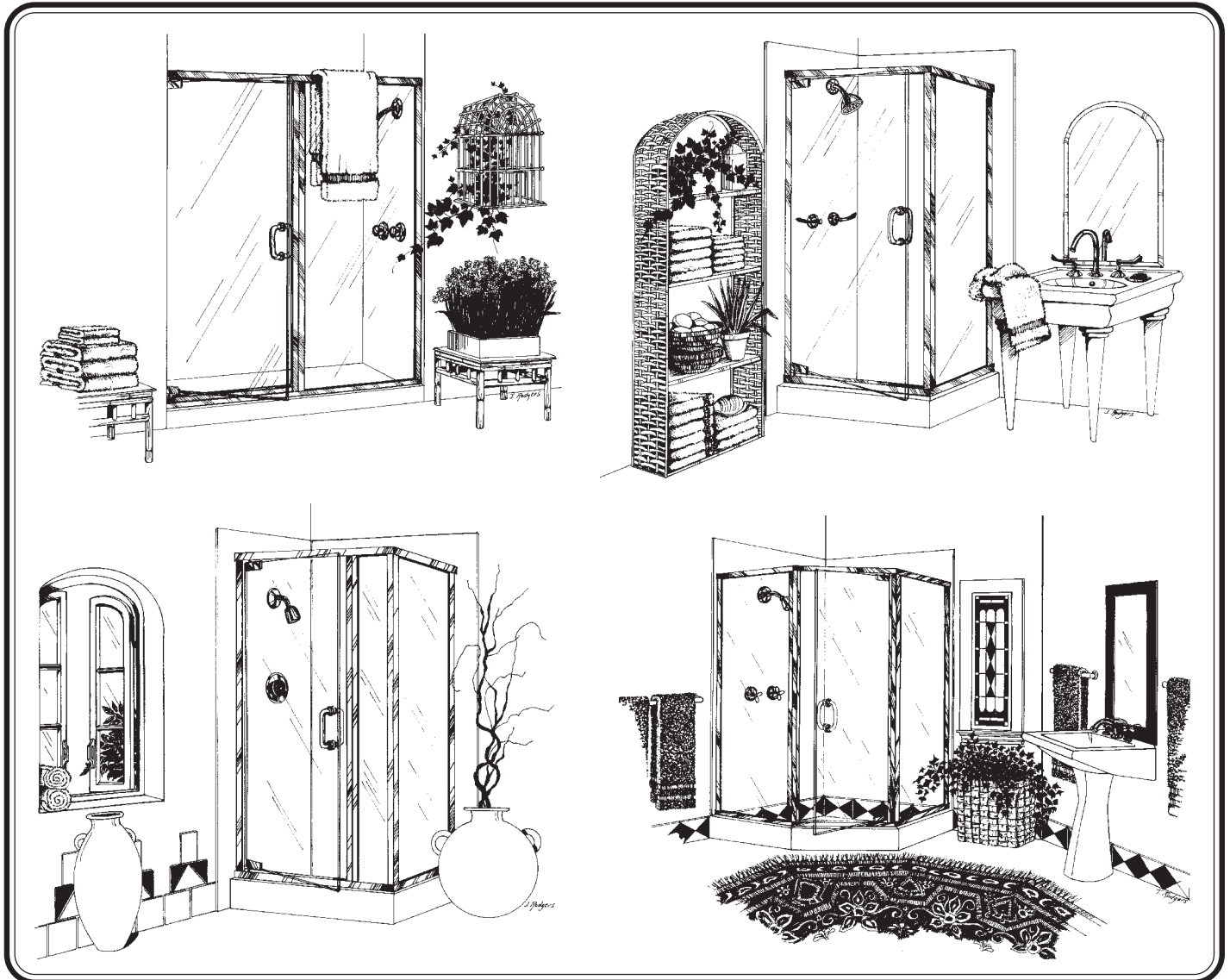

This Alumax 1090 Frameless Heavy Glass door panel kit is designed to be installed in our StikStall framework with an inline panel (1091), a return panel (1092), an inline and a return panel (1093), or a neo-angle unit (1094).

To ensure correct installation, this instruction supplement (packed with a glazed or KD door panel kit) is designed to be used with a StikStall Installation Instruction sheet (791, 792, 793, 794) that will be packaged with the corresponding StikStall frame kit. Each step in the primary instruction sheet will indicate whether it applies to all door types or if this supplement should be used. If your StikStall Instruction Sheet does not mention the use of a supplement before Step #1, then contact your dealer for the proper instruction sheet.

NOTE: Before beginning installation, check the walls of your shower enclosure for plumb. For proper operation of the gravity pivot mechanism, it is critical that the pivot jamb is installed absolutely plumb. Contact your dealer if you have installation problems.

CAUTION: The 1090 frameless door weighs 50 to 70 pounds, according to size. To prevent personal injury or damage, the door must be properly installed with the pivot jamb securely anchored. Please use a helper when hanging the door.

1090 PARTS LIST

- A. 2 Frame Inserts
- B. 2 Long Pivot Bushings
- C. 1 Pivot Jamb Bulb Vinyl
- D. 2 Door Jambs
- E. Snap-in Fillers
- F. 6 #8 x 1/4" Truss Head Screws
- G. 2 #6 x 3/8" Truss Head Screws
- H. 2 Short Pivot Bushings
- J. 1 Strike Jamb Vinyl
- K. 2 Pivot Blocks with Stainless Pins
- L. 2 #10 x 7/16" Square Head Set Screws
- M. 2 Door Rails
- N. 1 Glass Door Panel
- P. 6 Vinyl Rail Shims (3 sets)
- S. 1 Vinyl Drip Deflector
- T. 2 Nylon Handle Bushings
- U. 2 Handle Bases (Male)
- V. 4 Rubber Handle Gaskets
- W. 2 Handle Bases (Female)
- X. 2 #8 x 5/8" Flat Head Screws
- Y. 2 Door Handle Assemblies

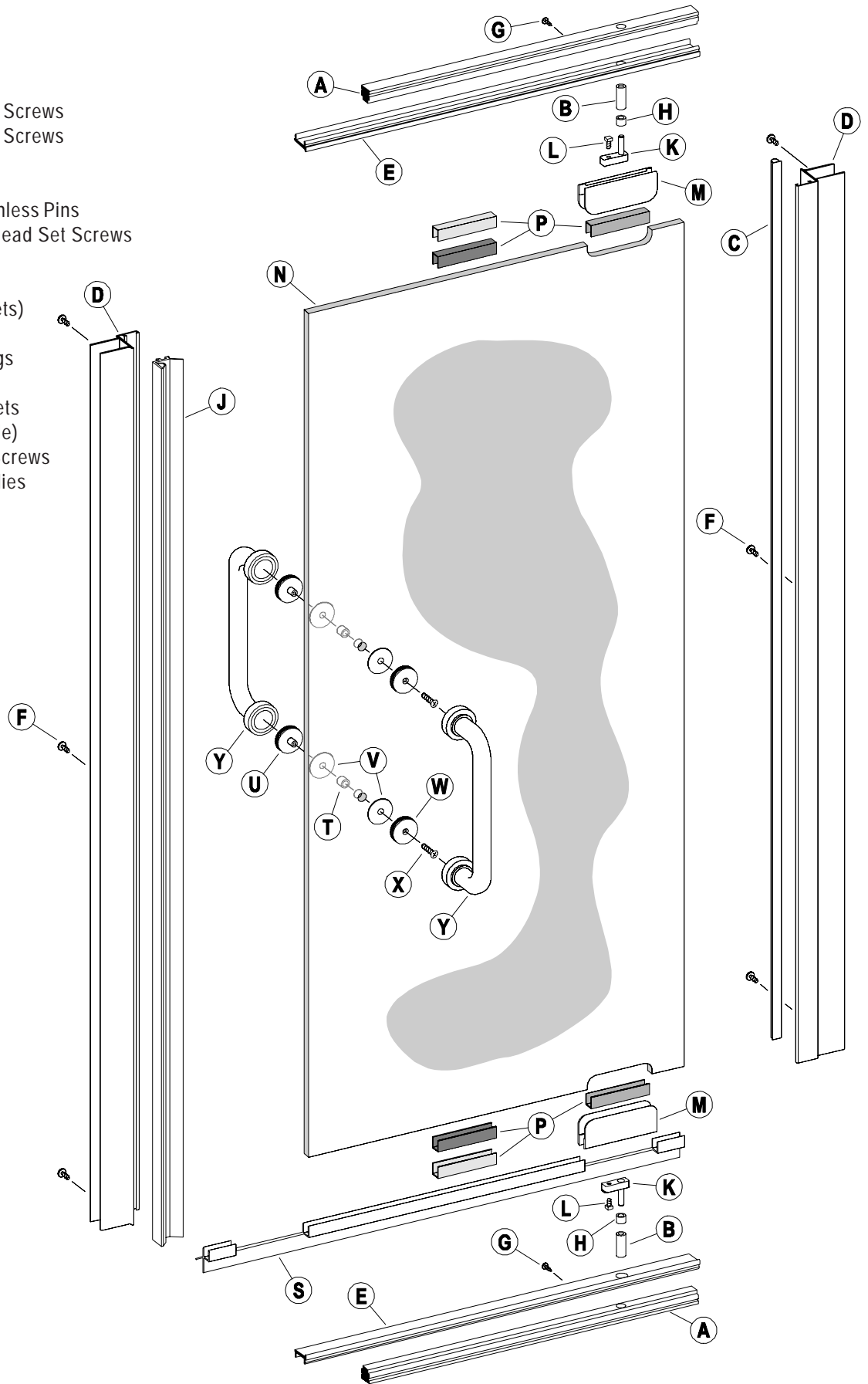

1 The 1090 Frameless Heavy Glass Door is completely reversible and may be installed pivot-left or pivot-right. For maximum waterproofing, the pivot jamb should always be opposite the shower head. Using the diagrams, determine the correct position for the door in your particular StikStall installation. This instruction supplement depicts a pivot-right installation.

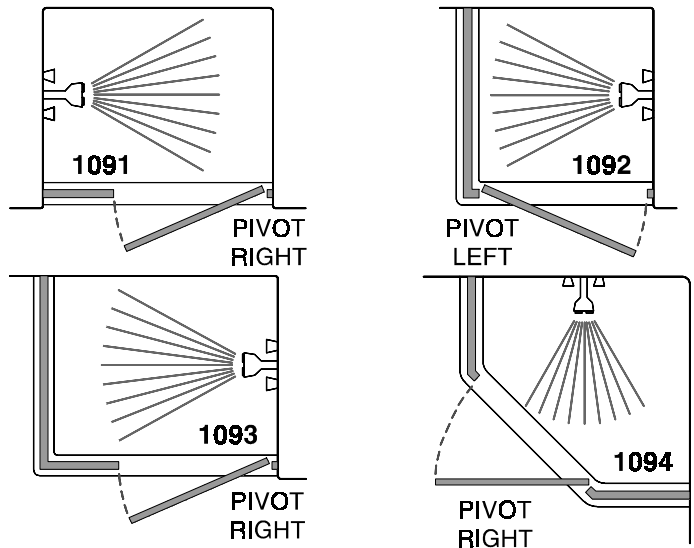

2 Select one of the frame inserts [A] and slide it into the appropriate curb section with the hole to the pivot side of the door opening. Insert one long pivot bushing [B] into the hole making sure the bushing is completely seated to the curb.

Slide the remaining frame insert into the appropriate header section with the hole to the pivot side. Insert the other long pivot bushing into the frame insert to the header.

Assemble the StikStall framing per the primary instruction sheet.

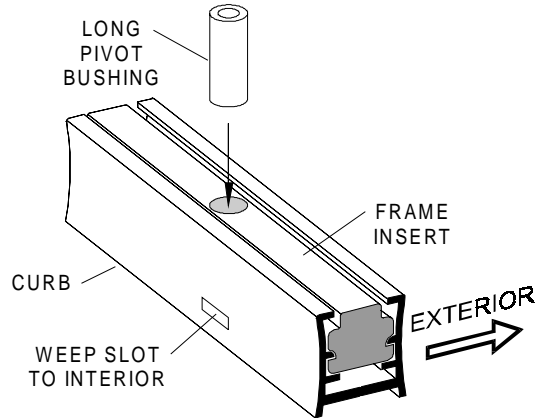

3 Slide the clear bulb vinyl jamb seal [C] into the slot in the pivot jamb [D] as shown. Slide the strike jamb vinyl [J] into the strike jamb [D]. Trim the vinyls even with the end of the jambs. The jamb vinyls can be secured with a small amount of clear glue or caulk or by carefully crimping the slot ends.

Press the door jambs over the wall jamb and/or framing posts.

Snap the fillers [E] into the header and curb between the door jambs [D] with the raised lip to the exterior and the pivot holes toward the pivot jamb. Center the curb filler in the curb between the pivot and strike jambs.

NOTE: The curb fills should be exactly 3/8" longer than the width of the 1090 door panel.

Align and secure the pivot jamb with three #8 x 1/4" truss head screws [F] as described in the primary StikStall instruction sheet. **Do not secure the strike jamb yet.**

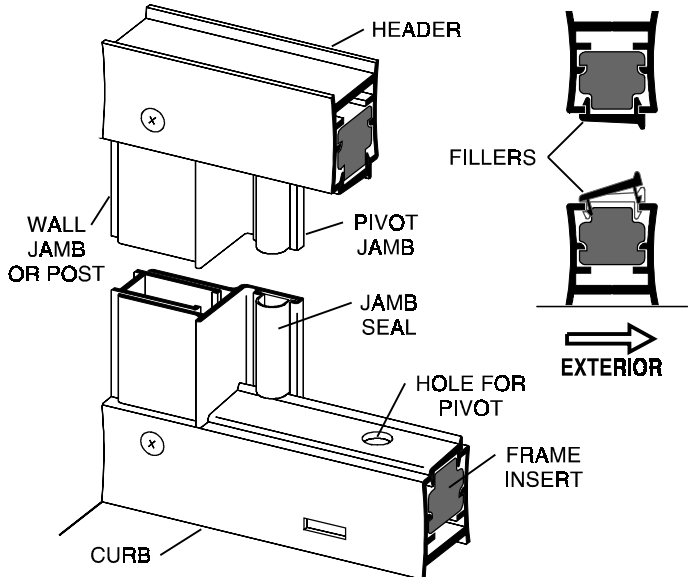

4

When both fillers are installed and the door jambs have been secured to the framing, align the pivot holes in the fillers [E] with the holes in the frame inserts [A]. Drill two 1/8" holes one half inch deep thru the interior face of the curb and header approximately 1" over from the hole in the snap fill (toward the center of the door opening). Install two #6 x 3/8" truss head screws [G] to secure the inserts to the framing and prevent movement.

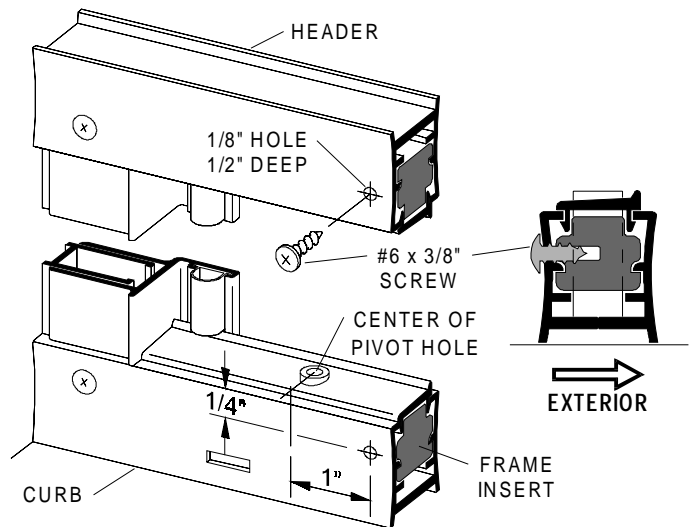

5

Place the short pivot bushings [H] onto the two pivot blocks [K]. Thread a #10 x 7/16" square head set screw [L] into each pivot block. Slide one pivot block into each door rail [M].

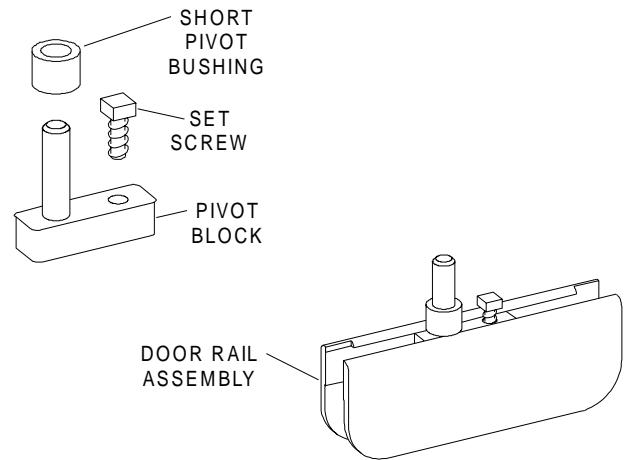

6

NOTE: Three sets of vinyl rail shims in varying thicknesses have been supplied with this unit to compensate for door glass that is thicker or thinner than nominal.

Place the glass door [N] in a secure position with each end accessible. Determine the top of the door by the logo painted on the glass. Place one piece of the vinyl rail shim [P] in each notch on the door. Position the top and bottom rail assemblies (Supplement Step #5) so that the set screw on the pivot block will be to the handle side of the door, as shown on the exploded view (page 3). With a hammer and wood block, carefully tap the rails onto the glass until the rails are approximately flush with the edge of the glass. To ease assembly, use glass cleaner as a lubricant.

CAUTION: The glass can chip if care is not taken to keep the rail square with the glass and centered in the notch.

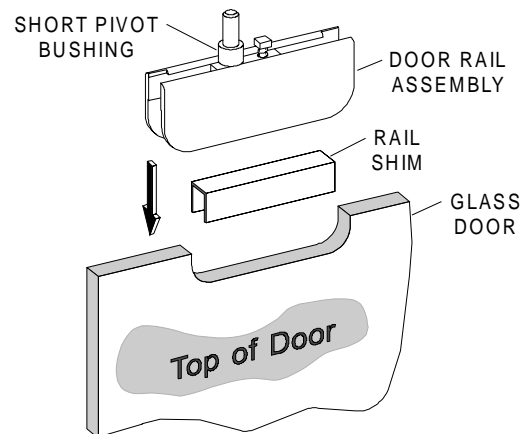

7

Set the pivot block locations by measuring 1 13/16" from the pivot edge of the glass door [N] to the side of the pivot block pin [H]. Tighten the set screws on both pivot blocks [K] with a 3/16" wrench.

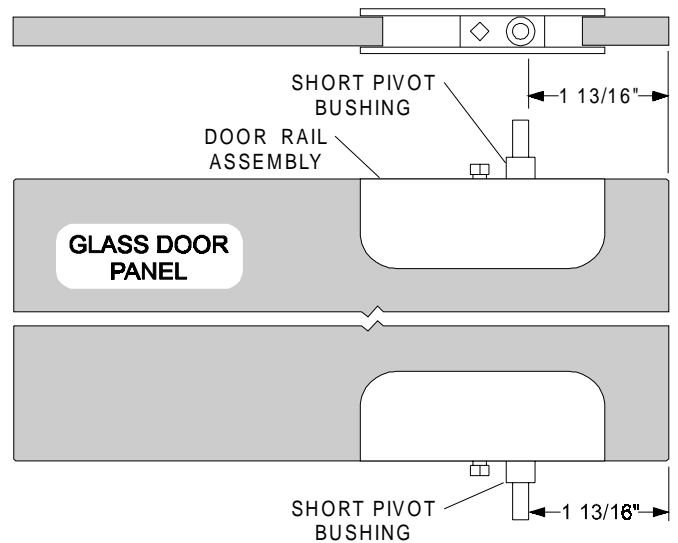

8

Hold the clear vinyl drip deflector [S] over the door panel bottom edge so that the rigid splash guard will be to the interior when the door is hung. Align the notched section with the bottom rail. Mark the drip deflector at the edge of the door. Remove the deflector and cut it off square at the mark. Carefully cut back 5/8" of the splash guard to prevent interference with the strike jamb.

Install the drip deflector by gently tapping it over the door and bottom rail with a hammer and wood block. To ease assembly, use glass cleaner for lubrication.

CAUTION: The drip deflector can be damaged if the door is stood upright with its full weight upon the deflector.

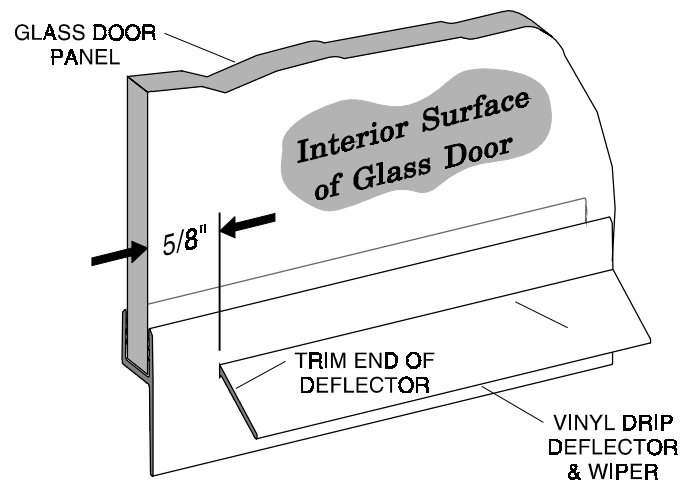

9

NOTE: Due to the size and weight of the door, this step should not be undertaken by only one person.

Remove the screws holding the header to the StikStall frame. Lift the door and set the bottom gravity pivot [H] into the hole in the curb filler [E], making sure the stainless steel pivot pin engages the female gravity pivot [B]. Hold the door vertical and align the upper pivot bushing [J] with the hole in the header filler (raising the header as necessary). Press the header down over the pivot bushing until the mounting screws can be reinserted thru the header into the jambs.

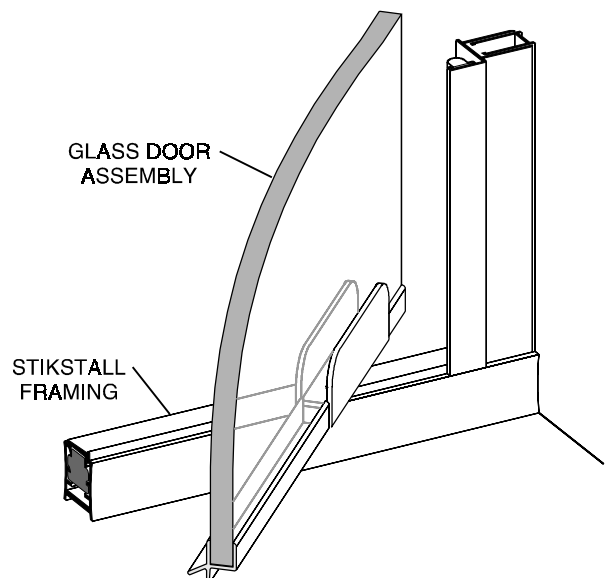

10

Place a nylon handle bushing [T] over the shank of the male handle base [U]. Slip a rubber washer [V] over the bushing. Install into one of the holes in the glass door [N]. Place a second rubber washer against the opposite surface of the glass, position the female handle base [W] over it and attach it securely with a #8 x 5/8" flat head screw [X].

Repeat for the second hole.

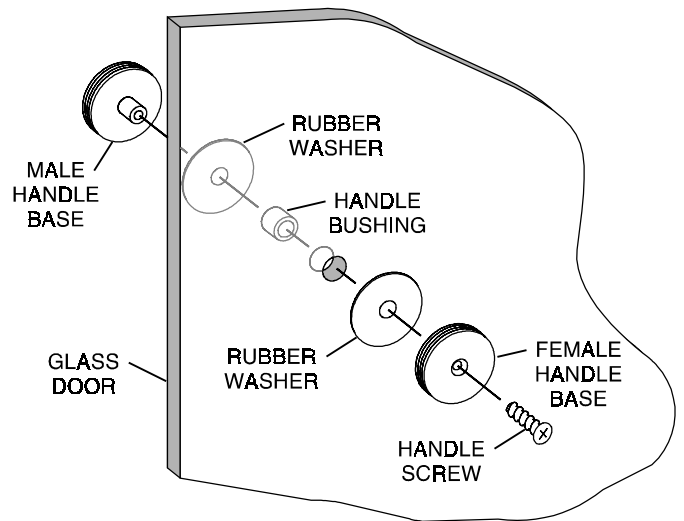

11

Hold one of the acrylic door handle assemblies [Y] against the handle bases and screw the outer handle rings onto the bases. Do not overtighten or use tools that might damage the finish.

Repeat for the remaining handle assembly.

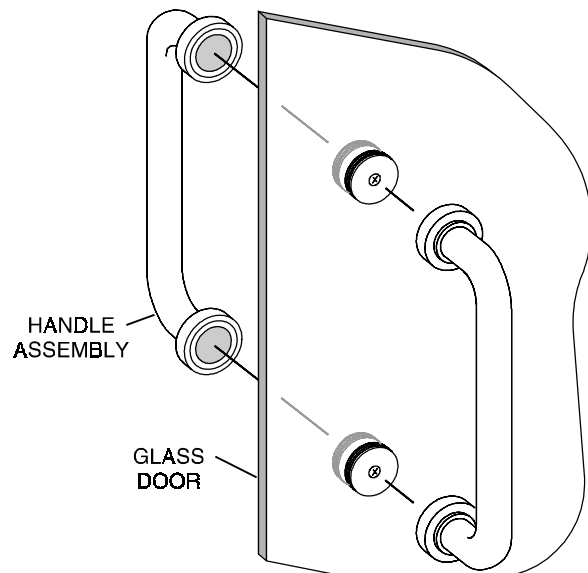

12

Use slight pressure on the strike jamb [D], pushing it against the door glass [N], to insure sufficient contact between the strike jamb vinyl [J] and the door glass [N]. Secure the strike jamb with three #8 x 1/4" truss head screws [F] as described in the primary StikStall instruction sheet.

